



*Newsletter 2021年10月号*

# Reduce Size, Weight and Power for Board and System Level Products

## 目次

- 1... Overview
- 2... Module Benefits
- 3... Boards Supported (VPX, VME, cPCI and PCIe)
- 4... Systems Supported
- 5... Design Win Examples



# NAI Configurable Open Systems Architecture™ (COSA®) for I/O Boards, SBCs, and Systems

A massively configurable, modular, intelligent approach offering unmatched breadth and scalability. COSA supports a wide range of complex and time-critical requirements in a distributed, intelligent, software-driven architecture that allows you to rethink the way you engineer power-critical and I/O-intensive mission systems.



[Additional Information](#)

# Module Benefits

Over 70 Modules Available (6 modules 6U VPX and VME, 3 Modules 3U VPX and cPCI)



**Dedicated SoC**

Input/Output	Measurement/Simulation	Communications
Analog-to-Digital	Synchro/Resolver to Digital	MIL-STD-1553/1760
Digital-to-Analog	Digital to Synchro/Resolver	RS-232/422/485
Discrete/PWM	LVDT/RVDT to Digital	ARINC-429/575
Isolated Discrete/PWM	Digital to LVDT/RVDT	CANBus
Differential Discrete	AC Ref./Exc.	Firewire
TTL	RTD/Thermocouple	Profibus
Relays	Strain Gage	Ethernet Switch
Chip Detect/Fuzz Burn	Accelerometer	Ethernet Dual NIC
Variable Reluctance	GPS/IRIG	TSN/TTE/AFDX/ARINC664p7

- Background Built-in-Test (BIT) monitors each channel during operation
- Dedicated FPGAs embedded on our smart modules enable you to rapidly create configurable mission systems while reducing or eliminating SBC overhead
- Each channel is programmable to customize for your application
- Each module has an Embedded Soft Panel GUI to provide easy access to program and monitor the data

[Function Modules](#)



# Board Options 6U VPX and VME supports up to 6 Modules

## I/O Motherboard Without Single Board Computers

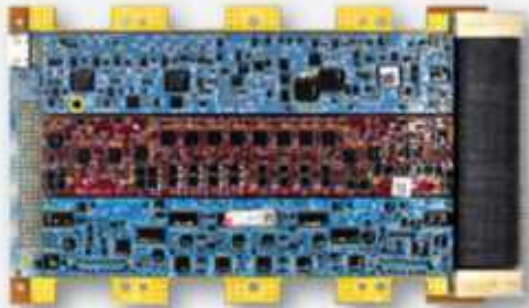

3U and 6U Form Factors

## I/O Motherboard With Single Board Computers

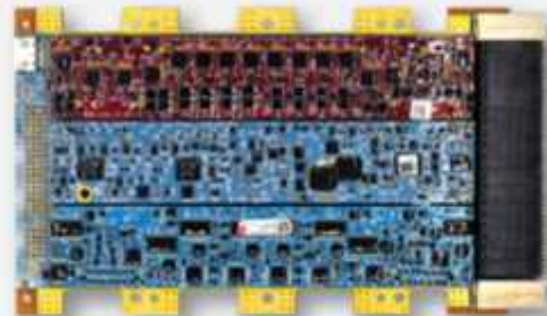

3U and 6U Form Factors

Intel® Core™ i7  
ARM® Cortex®-A9  
ARM® Cortex®-A53  
ARM® Cortex®-A72  
NXP® QorIQ® T2080

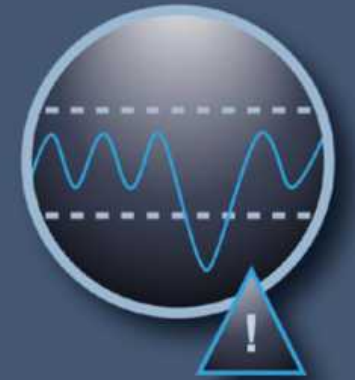

Health-Monitoring  
& Built in Test

- Available in Air-cooled and Conduction-cooled models
- Operating Temperature -40 to +85 Deg C, MIL-STD-810, MIL-STD-461
- Software Support Kits (SSKs) for multiple operating systems are supplied free of charge, with source code and board-specific library I/O APIs, to facilitate system integration. Each I/O function has dedicated processing, unburdening the system SBC from unnecessary data management overhead

VPX SBC's

[3U](#)

[6U](#)

VPX Multifunction I/O

[3U](#)

[6U](#)

3U cPCI SBC's

[ARM](#)

[Intel](#)

[PPC](#)

VPX Multifunction I/O

[3U](#)

[6U](#)

# 3U and 6U VPX Block Diagrams

## Block Diagram

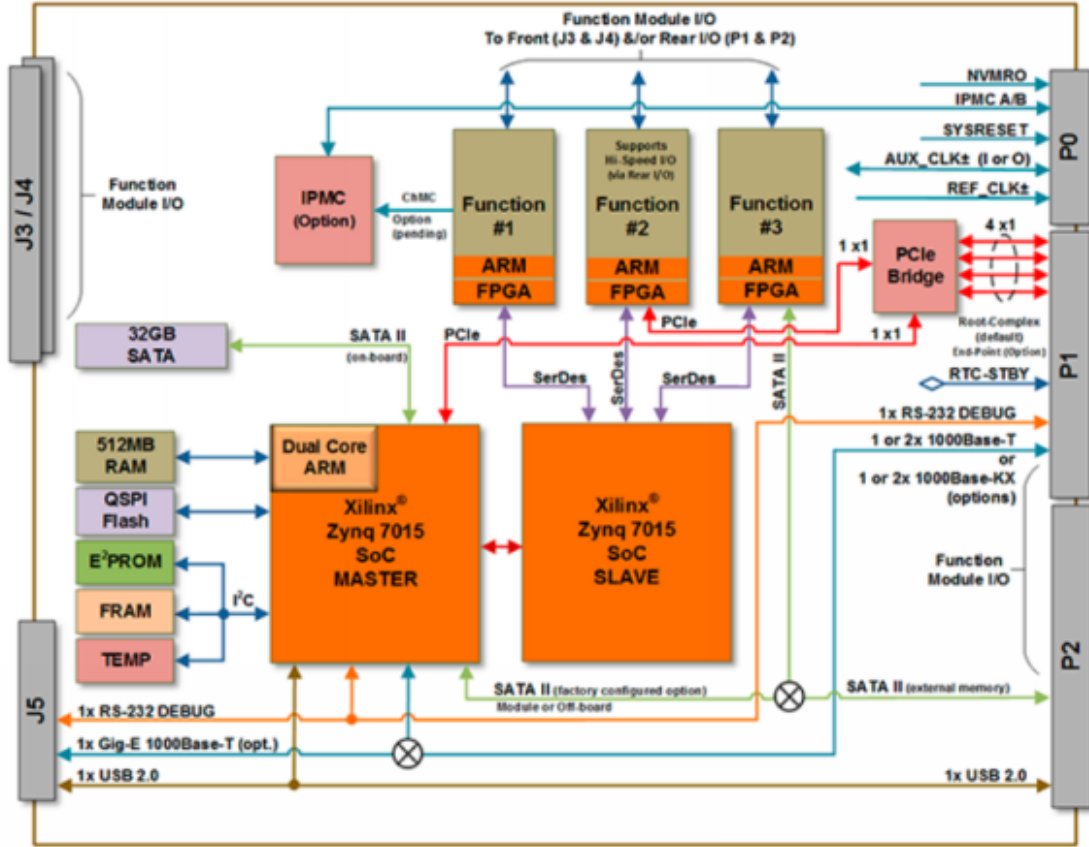

3U VPX Arm Processor



## Block Diagram

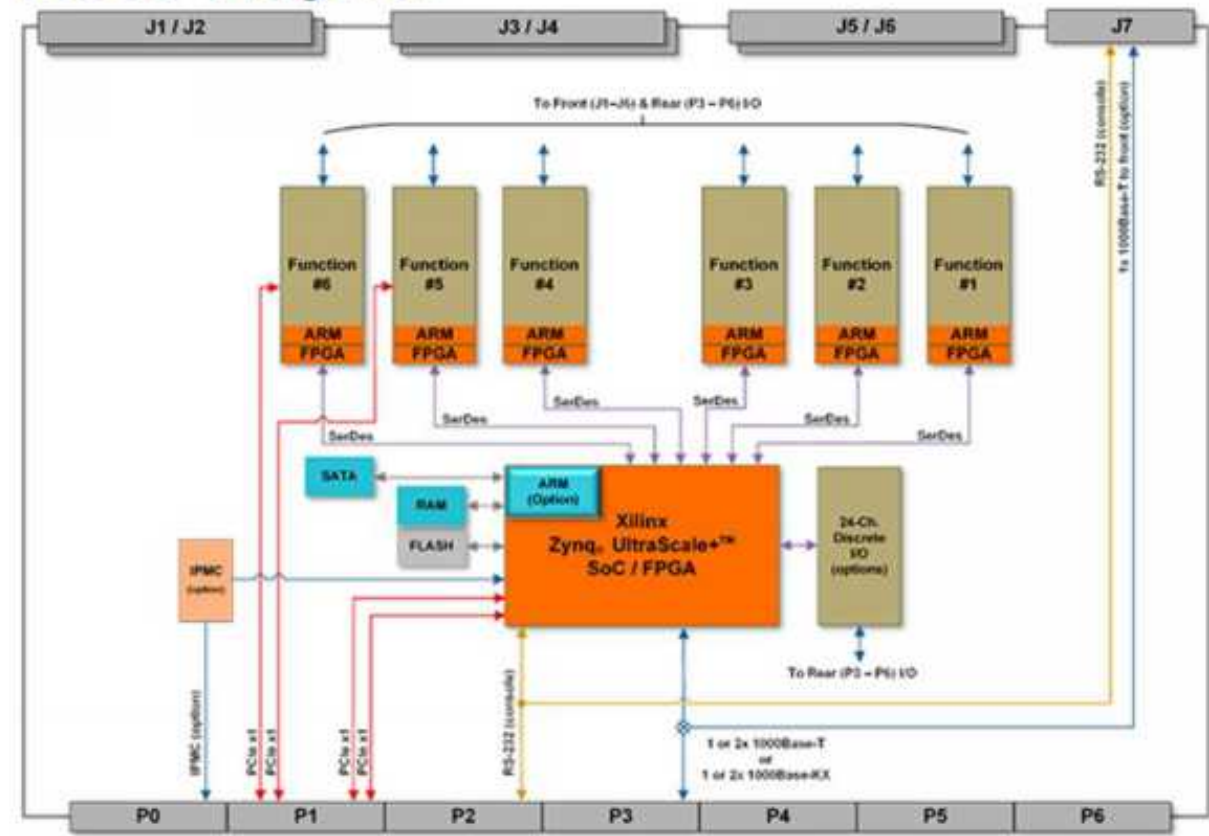

6U VPX Multifunction I/O



High Functional  
Density

# Systems – Complete Solution



- Ultra high-density
- More channels
- Less SWaP, little/no NRE



- Dedicated processing & signal analysis
- More programmability
- Eliminates SBC I/O processing overhead



## Design-in new CAPABILITY: continuous system self-testing



### Integrated Health & Usage Monitoring System

- Sensor/Load reporting information
- (open, short, increased current, Loss of Signal etc.)

Continuous BIT – executes on each individual module



## Configurations Available:

- [Data Acquisition \(DAQ\) systems](#)
- [Fire Control & Targeting \(FCT\) systems](#)
- [Integrated Vehicle Health Monitoring \(IVHM\) systems](#)
- [Remote Data Concentrators \(RDC\)](#)
- [Vehicle Management Systems \(VMS\)](#)



# I/O Module Features

## A/D

- The input range is field programmable for each channel.
- Each channel includes an anti-aliasing filter and a low-pass filter with a programmable breakpoint.
- All channels have continuous background Built-In-Test (BIT).
- The module(s) also include extended A/D FIFO buffering capabilities for greater storage/management of the incoming samples for post processing applications

## Discrete I/O

- 24 channels available as inputs or outputs
- Programmable for Input (voltage or contact sensing) or Output (current source, sink or push-pull) per channel/bank
- Programmable debounce circuitry with selectable time delay eliminates false signals resulting from relay contact bounce
- Built-in test runs in background constantly monitoring system health for each channel
- Ability to sense broken input connection and if input is shorted to +V or to ground
- Ability to read I/O voltage and output current for improved diagnostics (indicates if load is connected)

## D/A

- High-quality D/A conversion, 16-Bit/channel
- Continuous background BIT
- External trigger/synchronization
- Automatic shutdown protection with the results displayed in a status word
- Extended D/A FIFO buffering capabilities

## Differential Transceiver

- 16 channels available as inputs or outputs
- Programmable Pulse Width Modulation (PWM) output mode
- Pattern Generator output mode
- Programmable for fast or slow slew rates
- Programmable debounce circuitry with selectable time delay eliminates false signals resulting from relay contact bounce
- Built-in test runs in background constantly monitoring system health for each channel

# Communication Module Features

## MIL-STD-1553

- Independent (dual-redundant) MIL-STD-1553 interface channels: Bus Controller (BC), Remote Terminal (RT), and Bus Monitor (BM) or RT/BM combined mode operation
- 16K words on-board memory/channel
- IP-core register-compatible with DDC™ family of devices
- Message scheduling capability
- Asynchronous message capability
- Message FIFO capability

## 1394 (Firewire)

- 2-Channel, Tri-port per channel
- Open host controller/link-layer controller with a 3-port 1394b PHY per Channel
- IEEE 1394b / AS5643 Hardware Compatible

## TTE (AFDX)

- TTEthernet's 3 modes of operation: SAE AS6802 (TTE), ARINC 664 Part 7 (AFDX®), IEEE 802.3
- Supports 10/100/1000Base-T Mbps Ethernet

## ARINC429

- Receive/Transmit mode programmable per channel
- 100 kHz or 12.5 kHz operation per channel
- Transmit: 255 message FIFO or scheduled transmits per channel
- Receive: 255 message FIFO or mailbox buffering per channel
- Receive time stamping
- Continuous BIT
- Loop-back test
- Tri-state outputs
- High and Low speed Slew Rate outputs

## CANBus

- Eight independent galvanically-isolated, channels
- ANSI-C fully Compliant Network, Transport and DataLink layers
- Addressing can be set to be Self-configurable, Non-Configurable or Command-Configurable
- Transport and DataLink layers IAW SAE section J1939/21
- Network layer IAW SAE section J1939/81 for self-configurable or non-configurable device
- Adjustable baud rate with speeds up to 1 Mbit/sec supported



# Simulation and Measurement Module Features

## Synchro/Resolver Measurement

- 24-bit Accuracy 1 Arc Min. Supports Two-Speed Resolvers
- Synchro and Resolver inputs 2 – 90 V Rms, 47 Hz – 20 KHz
- Programmable Bandwidth 2 – 1280 Hz, Signal Thresholds
- Measures – Reference and Signal (Voltage and Frequency) and Velocity
- Background Continuous BIT test. The module incorporates major diagnostics that ensure that the user is alerted to channel malfunction.

## LVDT/RVDT Measurement

- 24-bit supports Accuracy +/- 0.025% Full Scale
- Supports 2,3 and 4 wire LVDT/RVDT's
- Inputs 2 – 90 V Rms, 47 Hz – 20 KHz
- Programmable Bandwidth 2 – 1280 Hz per channel
- Measures – Reference and Signal (Voltage and Frequency)
- Background Continuous BIT test. The module incorporates major diagnostics that ensure that the user is alerted to channel malfunction

## Synchro/Resolver Simulation

- 16-bit Resolution Accuracy 1 Arc Min. Supports 2-speed simulation
- Synchro and Resolver outputs 2 – 90 V Rms, 47 Hz – 20 KHz
- 1 channel 3 VA, 2 channels 2.2 VA, 3 channels .5 VA
- Short Circuit Protection
- The background Built-In-Test runs in the background where each channel is checked to a test accuracy of 0.2% FS. The testing is totally transparent to the user, requires no external programming, and has no effect on the operation of the module or card.

## LVDT/RVDT Simulation

- 16-bit Resolution Accuracy +/-0.1 % Full Scale
- Synchro and Resolver outputs 2 – 90 V Rms, 47 Hz – 20 KHz
- 1 channel 3 VA, 2 channels 2.2 VA, 3 channels .5 VA
- Short Circuit Protection
- The background Built-In-Test runs in the background where each channel is checked to a test accuracy of 0.2°. The testing is totally transparent to the user, requires no external programming, and has no effect on the operation of the module or card.

Additional Modules include [Thermocouple](#), [RTD](#), [Strain Gauge](#) and [Variable Reluctance](#)

# Embedded Soft Panel for Each Module

- Operating Systems Supported – Linux and Windows
- Easy to use GUI, No programming required

## Synchro Measurement

Basic S/D FIFO Interrupts (Under Development)

Chan.	Configuration					Measurements						Status - Latched/Realtime											
	Mode	Ang. Delta	Ref. Thresh	VLL Thresh	BW Sel.	BandWidth	Latched	Angle	Velocity	Freq.	Sig. Volt.	Ref. Volt.	Sin	Cos	En.	R. Loss	S. Loss	BIT	L. Loss	D. Angle	Open	Short	
<input checked="" type="checkbox"/>	Syn				Manua		<input type="checkbox"/>	0.0000	+0.0	0	0.00	0.00	0.0000	0.0000	<input type="checkbox"/>	<input checked="" type="checkbox"/>	<input checked="" type="checkbox"/>	<input checked="" type="checkbox"/>	<input checked="" type="checkbox"/>	<input checked="" type="checkbox"/>	<input checked="" type="checkbox"/>	<input checked="" type="checkbox"/>	<input checked="" type="checkbox"/>
<input checked="" type="checkbox"/>	Rsl	0.0000	0.00	0.00		0	<input type="checkbox"/>	0.0000	+0.0	0	0.00	0.00	0.0000	0.0000	<input type="checkbox"/>	<input checked="" type="checkbox"/>	<input checked="" type="checkbox"/>	<input checked="" type="checkbox"/>	<input checked="" type="checkbox"/>	<input checked="" type="checkbox"/>	<input checked="" type="checkbox"/>	<input checked="" type="checkbox"/>	<input checked="" type="checkbox"/>
<input checked="" type="checkbox"/>	Rsl	0.0000	0.00	0.00		0	<input type="checkbox"/>	0.0000	+0.0	0	0.00	0.00	0.0000	0.0000	<input type="checkbox"/>	<input checked="" type="checkbox"/>	<input checked="" type="checkbox"/>	<input checked="" type="checkbox"/>	<input checked="" type="checkbox"/>	<input checked="" type="checkbox"/>	<input checked="" type="checkbox"/>	<input checked="" type="checkbox"/>	<input checked="" type="checkbox"/>
<input checked="" type="checkbox"/>	Rsl	0.0000	0.00	0.00		0	<input type="checkbox"/>	0.0000	+0.0	0	0.00	0.00	0.0000	0.0000	<input type="checkbox"/>	<input checked="" type="checkbox"/>	<input checked="" type="checkbox"/>	<input checked="" type="checkbox"/>	<input checked="" type="checkbox"/>	<input checked="" type="checkbox"/>	<input checked="" type="checkbox"/>	<input checked="" type="checkbox"/>	<input checked="" type="checkbox"/>

Display Hex
 
 Enable D0 Test 0
  Enable D2 Test 0x00
  Enable D3 Test

Auto-Refresh: 100    Module FPGA Rev: 0.0

## D/A

Chan.	Configuration		Measurements	Status Latched/Realtime		
	Voltage Range (V)	Polarity		Bit	Open	O.C.
<input checked="" type="checkbox"/>	1.25	UniPolar	0.00000	<input checked="" type="checkbox"/>	<input checked="" type="checkbox"/>	<input checked="" type="checkbox"/>
<input checked="" type="checkbox"/>	1.25	UniPolar	0.00000	<input checked="" type="checkbox"/>	<input checked="" type="checkbox"/>	<input checked="" type="checkbox"/>
<input checked="" type="checkbox"/>	1.25	UniPolar	0.00000	<input checked="" type="checkbox"/>	<input checked="" type="checkbox"/>	<input checked="" type="checkbox"/>
<input checked="" type="checkbox"/>	1.25	UniPolar	0.00000	<input checked="" type="checkbox"/>	<input checked="" type="checkbox"/>	<input checked="" type="checkbox"/>
<input checked="" type="checkbox"/>	1.25	UniPolar	0.00000	<input checked="" type="checkbox"/>	<input checked="" type="checkbox"/>	<input checked="" type="checkbox"/>
<input checked="" type="checkbox"/>	1.25	UniPolar	0.00000	<input checked="" type="checkbox"/>	<input checked="" type="checkbox"/>	<input checked="" type="checkbox"/>
<input checked="" type="checkbox"/>	1.25	UniPolar	0.00000	<input checked="" type="checkbox"/>	<input checked="" type="checkbox"/>	<input checked="" type="checkbox"/>
<input checked="" type="checkbox"/>	1.25	UniPolar	0.00000	<input checked="" type="checkbox"/>	<input checked="" type="checkbox"/>	<input checked="" type="checkbox"/>
<input checked="" type="checkbox"/>	1.25	UniPolar	0.00000	<input checked="" type="checkbox"/>	<input checked="" type="checkbox"/>	<input checked="" type="checkbox"/>
<input checked="" type="checkbox"/>	1.25	UniPolar	0.00000	<input checked="" type="checkbox"/>	<input checked="" type="checkbox"/>	<input checked="" type="checkbox"/>
<input checked="" type="checkbox"/>	1.25	UniPolar	0.00000	<input checked="" type="checkbox"/>	<input checked="" type="checkbox"/>	<input checked="" type="checkbox"/>
<input checked="" type="checkbox"/>	1.25	UniPolar	0.00000	<input checked="" type="checkbox"/>	<input checked="" type="checkbox"/>	<input checked="" type="checkbox"/>
<input checked="" type="checkbox"/>	10.0	UniPolar		<input type="button" value="Clear"/>	<input type="button" value="Clear"/>	<input type="button" value="Clear"/>

## A/D

Channel	Mode	Range/BiPolar	Set V/A	Wrap (V)	Wrap (A)	BIT	O.C.Status
1	Current		0.000	0.000	0.000	<input checked="" type="checkbox"/>	<input checked="" type="checkbox"/>
2	Voltage		0.000	0.000	0.000	<input checked="" type="checkbox"/>	<input checked="" type="checkbox"/>
3	Voltage		0.000	0.000	0.000	<input checked="" type="checkbox"/>	<input checked="" type="checkbox"/>
4	Voltage		0.000	0.000	0.000	<input checked="" type="checkbox"/>	<input checked="" type="checkbox"/>
5	Voltage		0.000	0.000	0.000	<input checked="" type="checkbox"/>	<input checked="" type="checkbox"/>
6	Voltage		0.000	0.000	0.000	<input checked="" type="checkbox"/>	<input checked="" type="checkbox"/>
7	Voltage		0.000	0.000	0.000	<input checked="" type="checkbox"/>	<input checked="" type="checkbox"/>
8	Voltage		0.000	0.000	0.000	<input checked="" type="checkbox"/>	<input checked="" type="checkbox"/>
9	Voltage		0.000	0.000	0.000	<input checked="" type="checkbox"/>	<input checked="" type="checkbox"/>
10	Voltage		0.000	0.000	0.000	<input checked="" type="checkbox"/>	<input checked="" type="checkbox"/>
11	Voltage		0.000	0.000	0.000	<input checked="" type="checkbox"/>	<input checked="" type="checkbox"/>
12	Voltage		0.000	0.000	0.000	<input checked="" type="checkbox"/>	<input checked="" type="checkbox"/>
All	Voltage	1.25V/3.1	0			<input type="button" value="Clear"/>	<input type="button" value="Clear"/>

### Module Info

Module FPGA Rev: 0.0

# Software Support Kit for Each Module

- **Operating Systems Supported:**
  - Windows, VxWorks and Linux
- **Software Support Kit contains:**
  - Help documentation
  - Driver
  - Dynamic link library- DLL
  - VB or C#, Menu (.txt)
  - LabVIEW example
  - C++ example(s)
  - Portability files for other BSP Packages
- **All developed software is FREE**

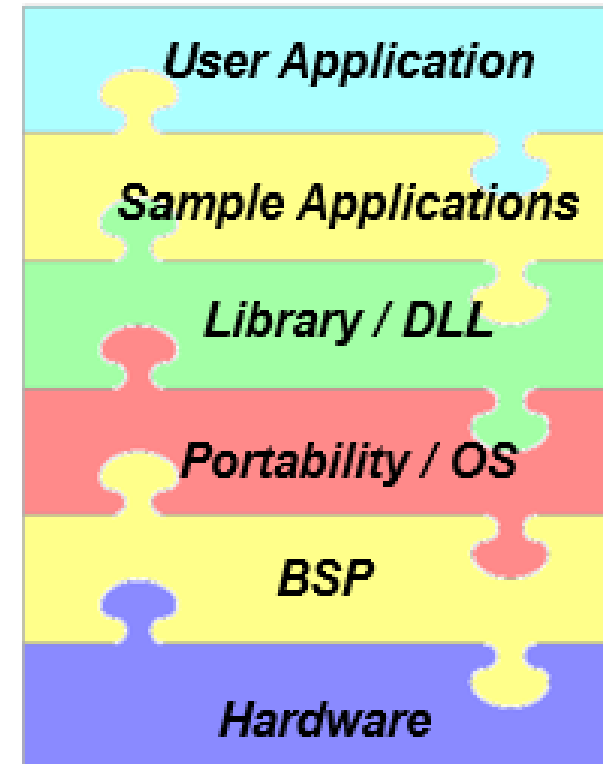



# Airborne Design-Wins



VME

PWM motor control and Power Supply



VPX

Discrete I/O, A/D, D/A, Strain Gauge,  
Thermocouple, RTD, Variable Reluctance,  
LVDT, 1553, 429 and RS-422



Small Form Factor System  
Over 100 I/O channels



Multiple NIU1A's

Serial, CANBus, 1553, A/D, RTD and  
Discrete I/O



cPCI

D/A, Synchro and LVDT Measurement and  
1553



System

Serial Communications, Discrete I/O, RTD  
and Power Supplies

# Shipboard/Submarine Design-Wins



VME - 12,000 Sensors  
A/D, D/A, Serial, ProfiBus, Discrete I/O, RTD,  
and 4-20 mA



System  
A/D, D/A, RTD channels; Discrete I/O, Serial,  
CANBus and ProfiBus



System  
Serial and 1553



System  
A/D, D/A, Discrete I/O, RS-232 and Power  
Supplies



VME  
Discrete I/O, A/D, D/A

TBD

# Ground Based and Ground Support Design–Wins



System  
Discrete I/O Synchro Measurement and  
Simulation



Commercial Aircraft  
Power Monitor



Landing Gear and Fuel System Testing  
A/D, D/A, Discrete I/O and LVDT Simulation



Flight Control Surface Testing  
LVDT/RVDT Simulation and Measurement





お問い合わせ先:

ティー・ピー・ティー株式会社

〒110-0008

東京都台東区池之端1-6-13 境会館5階

TEL: 03-5832-7350

URL: <http://www.tpotech.co.jp/>

e-mail: [sales.t@tpotech.co.jp](mailto:sales.t@tpotech.co.jp)

